



- OPTIONAL RS-232/RS-485 CONTROL
- 0.5kV TO 10kV & 2W TO 10W
- HIGH STABILITY & LOW NOISE & RIPPLE
- SIX-SIDED SHIELDED
- ARC & SHORT CIRCUIT PROTECTED
- LOCAL AND REMOTE CONTROL
- OEM CUSTOMIZATION AVAILABLE

MODULES

INTRODUCTION

Wisman's PM series of six-sided shielded are high performance products designed with hybrid topology of linear and switch mode power conversion techniques delivering lower noise with higher efficiency. It is applied to Photomultiplier Tubes (PMT), Solid state detectors, Ultrasonic transducers and so on. PM series can control by inside potentiometer and outside potentiometer or computer. An optional RS-232 or RS-485 is available. PM module is available as either a positive or negative supply that is ideal for OEM applications.

TYPICAL APPLICATIONS

Mass spectrometry, Photomultiplier Tubes (PMT), Microchannel plates (MCP), Proportional Counters, GM Tube, Avalanche Photo Diode (APD), Solid state detectors, Ionization Chambers, gas chromatography, Electron multiplier Detectors, Nuclear Instruments, Electrophoresis, DNA sequencing, Radiation counter, Electron Beam, Ion Beam, High voltage bias, Hipot Testing, Precision Lenses Image Intensifiers, Semicon-ductor Testing, Electrostatic discharge Testing, Provides power to the pulse power, Capacitor Discharging, Life Sciences, Medical chemical Applications, Science Laboratory Applications Industrial Applications.

PM SELECTION TABLE

kV	mAPW	MODEL	RIPPLE(mVpp)	kV	mAPW	MODEL	RIPPLE(mVpp)	kV	mAPW	MODEL	RIPPLE(mVpp)
0.5	4.0 2	PM0.5*2	5	2	1.0 2	PM2*2	2	5	0.4 2	PM5*2	5
	10.0 5	PM0.5*5	5		2.5 5	PM2*5	2		1.0 5	PM5*5	5
	20.0 10	PM0.5*10	5		5.0 10	PM2*10	2		2.0 10	PM5*10	5
1	2.0 2	PM1*2	2	3	0.67 2	PM3*2	3	7.5	0.27 2	PM7.5*2	15
	5.0 5	PM1*5	2		1.67 5	PM3*5	3		0.67 5	PM7.5*5	15
	10.0 10	PM1*10	2		3.33 10	PM3*10	3		1.33 10	PM7.5*10	15
1.5	1.33 2	PM1.5*2	2	4	0.5 2	PM4*2	5	10	0.2 2	PM10*2	30
	3.33 5	PM1.5*5	2		1.25 5	PM4*5	5		0.5 5	PM10*5	30
	6.67 10	PM1.5*10	2		2.5 10	PM4*10	5		1.0 10	PM10*10	30

PM SELECTION EXAMPLE

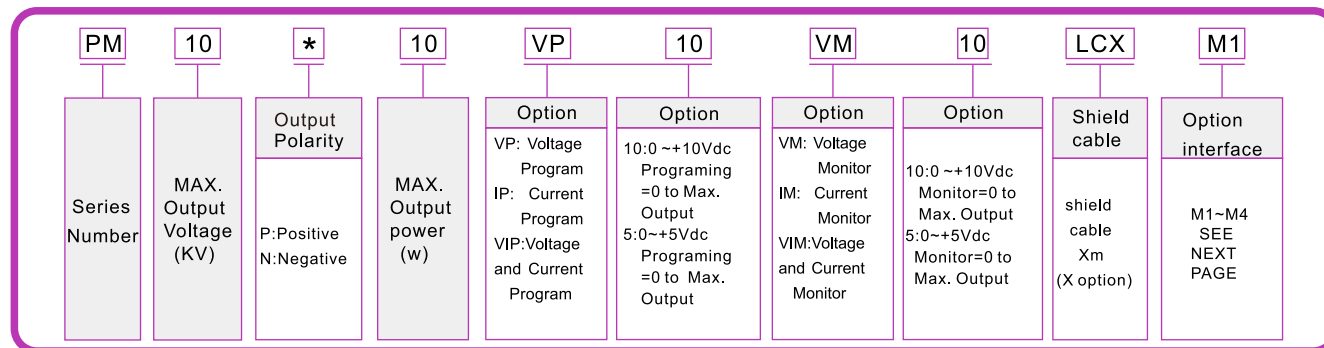

SPECIFICATIONS

PARAMETER	DESCRIBE
Input Voltage	+24Vdc ~ 2Vdc@ 1A
Output Voltage	0.5kV~10kV optional
Stability	~ 0.001% per hour, after ~ hour warm-up.
Temperature Coefficient	25ppm/ ~ .
Ripple	See ~ PM SELECTION TABLE ~ .
Reference Voltage	+10Vdc ±1%.
Output Voltage Accuracy	~ 2%/Vp-in=+10Vdc.
Voltage/Current Monitor	0~+10Vdc corresponds to 0 to maximum output,Zout=10kW. Accuracy: ~ 1%.
Voltage Local Programming	By internal potentiometer (0~ +10Vdc for 0 to maximum output)
Voltage Remote Programming	By external 20kW potentiometer or external voltage control corresponds to 0~100% maximum output (0~+10Vdc, Zin=100kW, Accuracy: ±1%).
Current Remote Programming	At VP, providing steady 100% over current protection;At IP,VIP, input 0~ +10Vdc, Linear corresponds to 0~100% rated output,Zin=100KW
Voltage Load Regulation	0.01%of rated output voltage for full load change.
Voltage Line Regulation	~ 0.001% (input voltage changes ~ 1Vdc).
Cooling	Convection cooled
Accessory	Plug type:9B3.9608; Wire metal terminal: 9B3.96T
Operating Temperature	0°C~50°C .
Storage Temperature	-40 ~ ~+85 ~ .
Humidity	20%~85% Rh, non-condensing.
Dimensions	See ~ PM Dimensions
Weight	400g

PM 8 PIN CONNECTOR DIAGRAM

M1:ANALOG 8 PINS INTERFACE

M2:ANALOG 8 PINS INTERFACE(CURRENT PROGRAMMING)

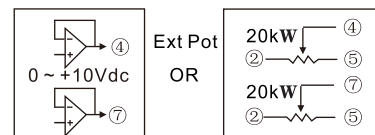
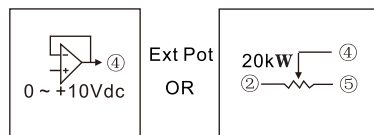
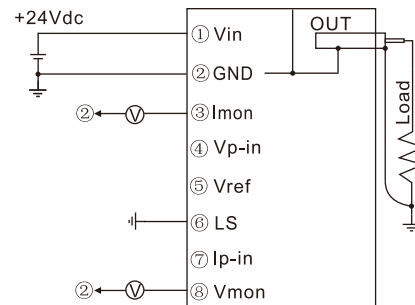
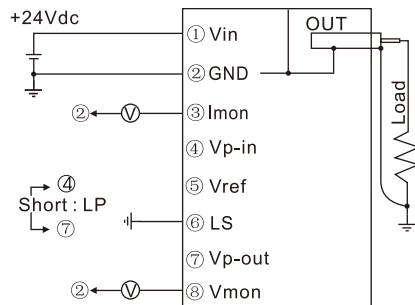



PM 8 PIN CONNECTOR DIAGRAM

M3: RS-232 [Ⓛ]

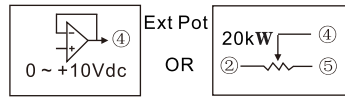
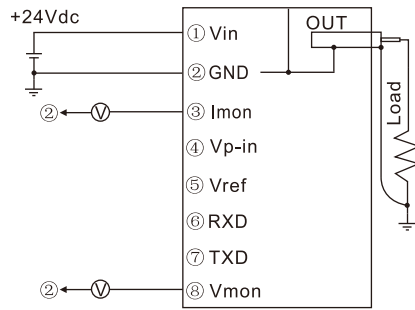

M4: RS-485 [Ⓛ]

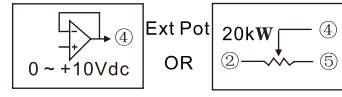
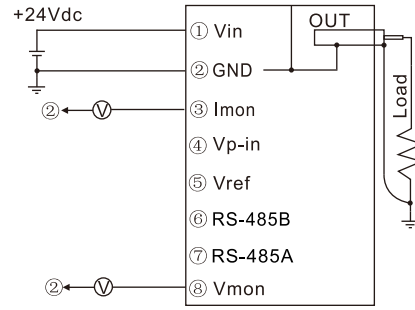

DIMENSIONS

DIMENSIONS:in.[mm]

