

- HIGH STABILITY: 10PPM/HR
- ULTRA LOW NOISE 10PPM
- ULTRA LOW TEMPERATURE COEFFICIENT 10PPM/°C
- EXTRA-SMALL AND LIGHT WEIGHT
- SIX-SIDED SHIELDED
- EXTERNAL POTENTIOMETER OR AN EXTERNAL VOLTAGE REFERENCE
- OEM CUSTOMIZATION AVAILABLE

## INTRODUCTION

Wisman's MC series of high voltage 0.5~2W micro-modules that provide output voltages ranging from 100V to 2kV. MC modules are compact six-sided shielded modules with ultra-low noise, high stability and ultra-low temperature coefficient. All models are provided with external potentiometer or an external voltage monitoring panel. This series modules have protection functions including over current protection, arc fault protection and short circuit protection.

## TYPICAL APPLICATIONS

Mass spectrometry photomultiplier tubes (PMT), solid state detectors, Piezo crystal devices, ultrasonic transducers, microchannel plates (MCP), spectroscopy, scintillation counters, electron multiplier detectors, nuclear Instruments, electrophoresis, semiconductor testing, DNA sequencing, radiation counter, electron and ion beams, electrostatic chuck, high voltage, bias hipot testing, precision lenses, image intensifiers, semiconductor testing, chemical applications, laboratory applications, industrial application supplies.

## MC SELECTION TABLE

kV	mA	P(W)	MODEL	kV	mA	P(W)	MODEL	kV	mA	P(W)	MODEL	kV	mA	P(W)	MODEL
0.5	1.00	0.5	MC0.5*0.5	1	0.50	0.5	MC1*0.5	1.5	0.33	0.5	MC1.5*0.5	2	0.25	0.5	MC2*0.5
	2.00	1	MC0.5*1		1.00	1	MC1*1		0.67	1	MC1.5*1		0.50	1	MC2*1
	4.00	2	MC0.5*2		2.00	2	MC1*2		1.33	2	MC1.5*2		1.00	2	MC2*2

## MC SELECTION EXAMPLE

MC	2	*	2	VP	5	VM	5	LS	12
Series Number	Maximum Output Voltage (kV)	Option Output Polarity P: positive N: negative	Maximum Output Power (W)	Option Programming Voltage given	Option Programming Proportion 10:0~+10Vdc=0 to max. output 5:0~+5Vdc=0 to max. output 2.5:0~+2.5Vdc=0 to max. output (only for +5Vdc input)	Option Monitor Voltage display	Option Monitor Proportion 10:0~+10Vdc=0 to max. output 5:0~+5Vdc=0 to max. output 2.5:0~+2.5Vdc=0 to max. output (only for +5Vdc input)	Option Start Way Low level start	Option Input Voltage 24:+24Vdc input 15:+15Vdc input 12:+12Vdc input 5:+5Vdc input



**MC SPECIFICATIONS**

PARAMETER	DESCRIBE
Input Voltage	+12Vdc±2%. input current≤ 350mA. +24Vdc±2%, +15Vdc±2%, +5Vdc±2% input available
Output	0.5kV, 1kV, 1.5kV, 2kV available
Stability	0.001% after a 30 minute warm-up period.
Temperature Coefficient	<10ppm /°C.
Ripple	0.001% p-p of maximum output voltage.
Voltage Programming	By external 20kΩ potentiometer or external voltage control(Vp-in)0~+5Vdc. Zin = 100kΩ.
Voltage Monitor	0~+5Vdc=0 to 100% output, Zout=20kΩ. Accuracy=± 1%.
Voltage Line Regulation	±0.001% (input voltage change ±2%).
Voltage Load Regulation	±0.01% (no load to full load change).
Output Rise Time	50ms.
Operating Temperature	0°C~+50 °C.
Storage Temperature	-40°C~+85°C.
Humidity	0%~90% RH, non-condensing.
Cooling	Convection cooled.
Dimensions	0.94" H x 0.47" W x 1.81" D(24.00mm x 12.00mm x 46.00mm).
Weight	25g.

**A**  
**MICRO-MODULES**

**MC PIN INFORMATION**

PIN	DESCRIPTION
1	Input voltage +12Vdc±2%, Option +24Vdc±2%, +15Vdc±2%, +5Vdc±2%
2	Power Ground
3	Signal Ground
4	Voltage Programming, 0~5Vdc = 0~100% of rated output, Zin=100kΩ
5	+5Vdc Reference
6	HV Output
7	Voltage monitor, 0~5Vdc = 0~100% of rated output, Zout=20kΩ
8	LS: GND=ON, OPEN=OFF(OPTION)

**OUTPUT VOLTAGE CONTROLLING CHARACTERISTIC**

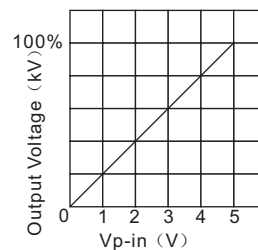

**MC DIMENSIONS: In. [mm]**

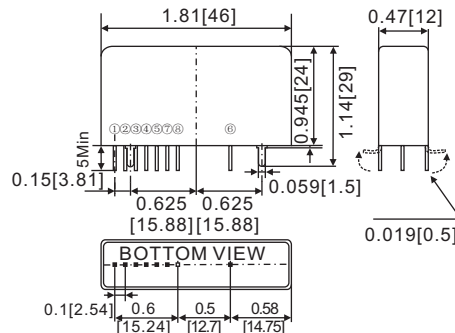

**MC CONNECTION DIAGRAM**

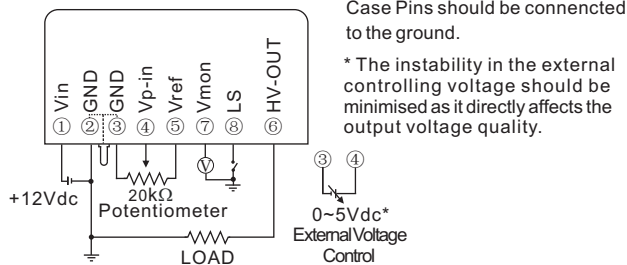

**DRILLING DATA FOR PCB BOARD: In. [mm]**

